



INSTALLATION, OPERATION & MAINTENANCE INSTRUCTIONS

SENTINEL®

MOTORIZED BALL VALVE WITH ADJUSTABLE CYCLE TIME

Model MDV400L

FIGURE 1

NOTES:

1. RATED PRESSURE: BRASS 600 PSIG COLD WOG
SS 900 PSIG COLD WOG
2. VALVES ARE FULL PORT 2 PIECE BALL VALVES
3. AVAILABLE ELECTRICAL: -115VAC-1PH-50/60HZ, Max current 1.7 amps
-230VAC-1PH-50/60HZ, Max current 0.9 amps
-12VDC, Max current 1.7 amps
-24VDC, Max current 0.9 amps

(DC Voltage units are supplied with power cords but without plug)

4. TIME SETTINGS:
Open Time: 1 second to 99 minutes & 59 seconds at 1 second increments.
Closed Time: 1 minute to 99 hours & 59 minutes at 1 minute increments
5. NEMA 4 ENCLOSURE
6. AMBIENT TEMPERATURE OPERATING RANGE: 10 TO 120°F
7. VALVE INTERNAL MATERIALS

- BRASS VALVES:** BALL-CHROME PLATED BRASS
STEM- BRASS
SEAT-PTFE
SEAT BACKUP RING-VITON
- 316SS VALVES:** BALL-316SS
STEM-316SS
SEATS-RPTFE
SEAT BACKUP RING-VITON

*NOTE: Display may be sluggish at temperatures below 10°F and darkened at temperatures approaching 110°F (for best results, keep out of direct sunlight).

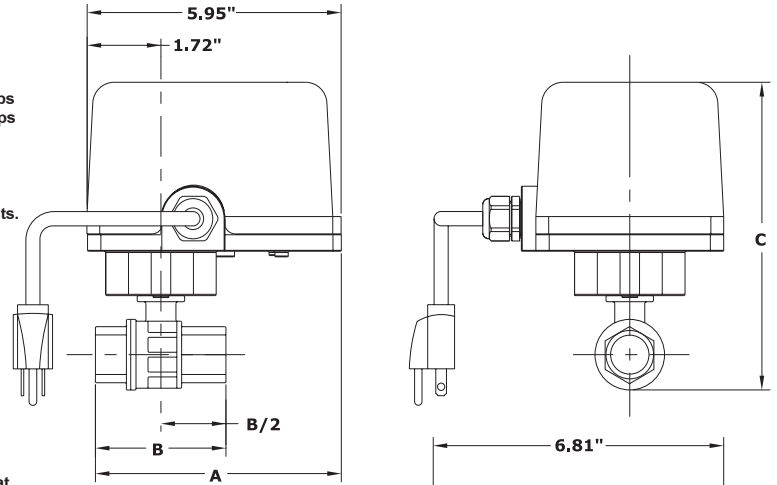

VALVE SIZE (NPT)	VALVE MATERIAL	DIMENSIONS			WEIGHT (LBS)	ACTUATOR TORQUE (IN/LBS)	FLOW COEFFICIENT CV
		A	B	C			
1/2"	BRASS	5.55	2.63	6.52	8.16	150*	19.0
3/4"		5.73	2.99	6.72	8.39	150*	34.4
1"		5.90	3.34	7.23	8.83	150*	50.2
1-1/4"		6.06	3.66	7.56	9.70	150*	103.7
1-1/2"		6.30	4.13	8.32	10.65	150*	268.4
2"		6.63	4.80	8.91	12.96	300	309.2
2-1/2"		7.28	6.10	9.90	16.14	600	629.0
3"	7.67	6.88	10.72	21.16	600	1018.2	
1/2"	STAINLESS STEEL (316SS)	5.55	2.64	6.83	8.18	150*	19.0
3/4"		5.77	3.07	6.99	8.67	150*	34.4
1"		6.00	3.55	7.63	9.66	150*	50.2
1-1/4"		6.20	3.94	8.03	10.42	150*	103.7
1-1/2"		6.43	4.41	8.87	11.65	150*	268.4
2"		6.89	5.32	9.61	14.88	300	309.2

* ACTUATOR TORQUE FOR UNITS WITH DC VOLTAGE IS 300 IN/LBS.

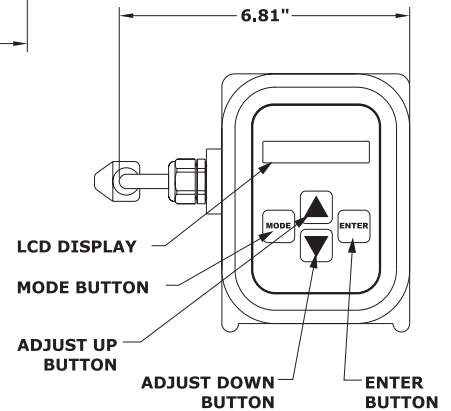

Thank you for buying this product.

For optimum performance and safety, please read and understand all instructions before installation.

Personnel must use safe working practices and observe all applicable local and international regulations, safety, health and legal requirements when installing and operating this product. Improper operation or maintenance of this product could be potentially dangerous resulting in an accident causing injury or death. Van Air Systems cannot anticipate every possible circumstance, which represents a potential hazard. The Warnings in this manual cover the most common potential hazards and are therefore not all-inclusive. The installation and maintenance of this product must be in strict accordance with this instruction manual or the warranty will be invalidated.

WARNINGS

- DO NOT REMOVE OR REPLACE ANY PART OF THE PRODUCT WHILE IT IS UNDER PRESSURE. SERIOUS PERSONAL INJURY AND/OR DAMAGE TO THE PRODUCT MAY RESULT.
- DO NOT OPERATE THE PRODUCT IF THERE ARE ANY PRESSURE LEAKS. IF A LEAK IS PRESENT, THE PRODUCT MAY BE UNSAFE TO OPERATE. REMOVE THE PRODUCT FROM SERVICE IMMEDIATELY.
- DO NOT OPERATE THIS PRODUCT ABOVE ITS MAXIMUM OPERATING PRESSURE AND/OR TEMPERATURE.
- WHEN INSTALLING THIS PRODUCT, BE SURE TO COMPLY WITH ALL LOCAL, STATE, INTERNATIONAL, AND/OR GOVERNMENT LAWS, RULES, REGULATIONS AND CODES APPLICABLE TO YOUR INSTALLATION.
- DO NOT INSTALL THIS PRODUCT IN A MANNER THAT DISCHARGES TOWARDS PEOPLE OR EQUIPMENT. SERIOUS INJURY AND/OR DAMAGE MAY RESULT.
- PROPER DISPOSAL OF DRAINED LIQUIDS THROUGH THIS PRODUCT ARE THE RESPONSIBILITY OF THE USER.

1.0 DESCRIPTION OF NORMAL OPERATION:

1.1 This product consists of a quarter turn ball valve mated to an electric actuator with a fully adjustable timer controller. The product is designed for mounting in a pipe-line requiring adjustable set closed times and adjustable set open times. A common application is draining fluids from compressed air system components such as separators, filters, airlines and receiver tanks. The timer is set at the factory to open the valve for 10 seconds every 2 hrs.

2.0 INSTALLATION INSTRUCTIONS: (Reference Figure 2)

- 2.1 Carefully unpack the valve from its shipping box or boxes. Check for visible signs of damage immediately file a claim with the carrier if damage is found. Do not install a damaged valve or actuator. Note: 2" valves and larger will be shipped in two boxes, one containing the valve and one containing the actuator. Smaller valves are shipped with actuator installed.
- 2.2 2" valves and larger will require installing the actuator after installing the valve in the line (See Figure 3).
- 2.3 Make sure that all pressure is removed from the line where the valve is to be installed. Make precautions to ensure the line remains free of pressure during the installation process.
- 2.4 Check the line for obstructions and clean as required.
- 2.5 Make sure all components and parts you are installing meet the temperature and pressure ratings of your system. (piping, manual valves, fittings, or electrical parts are not included)
- 2.6 Install a tee onto the line with the outlet facing down. Install a nipple and manual ball valve on the tee facing down. This is for bypassing the timer valve if it is not operational for any reason.
- 2.7 Install an isolation valve on the remaining opening. Close both manual valves and install a nipple and union on the isolation valve.
- 2.8 Install the valve after the union and install all additional piping downstream of the valve and bypass valve per your local requirements.
- 2.9 Locate a suitable power source and verify it meets the requirements of your valve (see valve label). Wire the valve using the cord included or conduit taking all precautions necessary to meet all required electrical codes for your location. Verify your timer valve is in the closed position and that timing is per your needs.
- 2.10 Review steps 2.1 through 2.9 to verify no steps were skipped.
- 2.11 Slowly pressurize the system. Once the system is fully pressurized, slowly open the isolation valve and check the system for leaks. In the event a leak is discovered, remove pressure from the system and repair before proceeding.
- 2.12 Your valve is now installed and ready for operation.

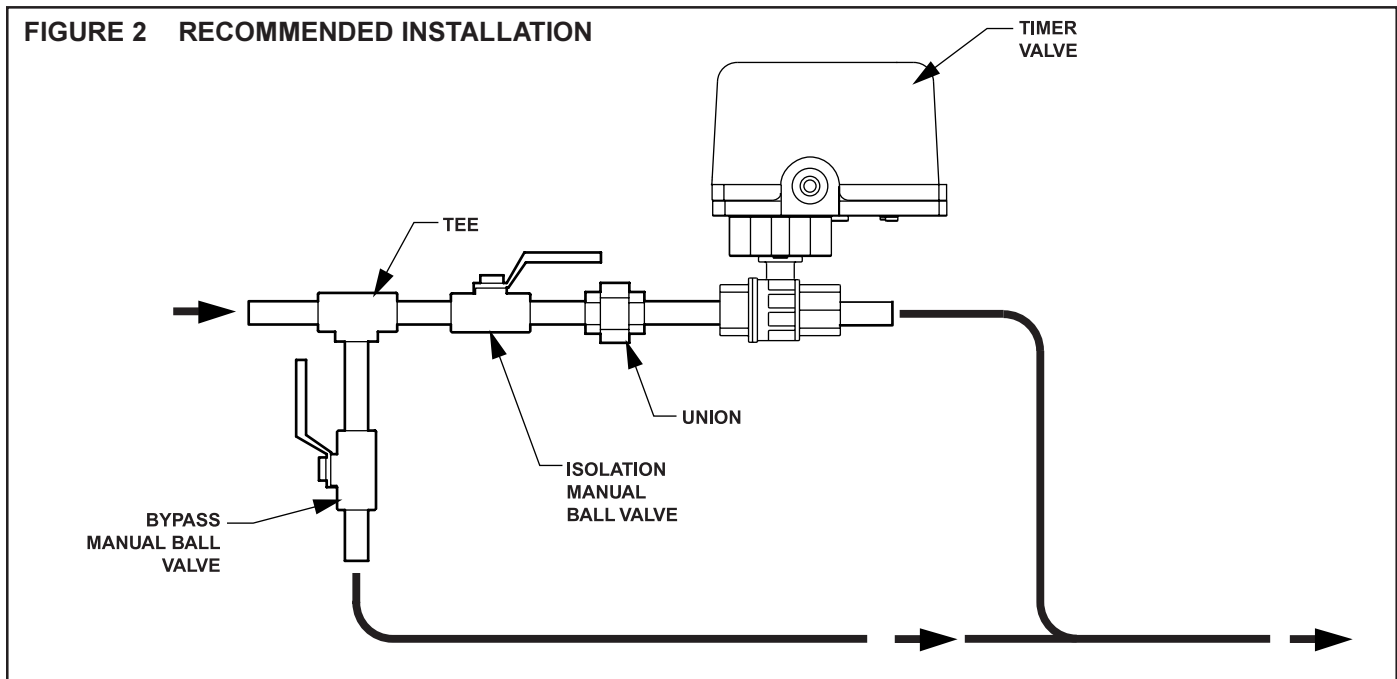

CAUTION: DO NOT INSTALL MORE THAN ONE FLOW SOURCE PER VALVE. MULTIPLE SOURCES WILL HAVE VARIED PRESSURES RESULTING IN HIGHEST TO LOWEST CONTAMINATION.

FIGURE 3 ASSEMBLY OF ACTUATOR AND VALVE (2" AND LARGER)

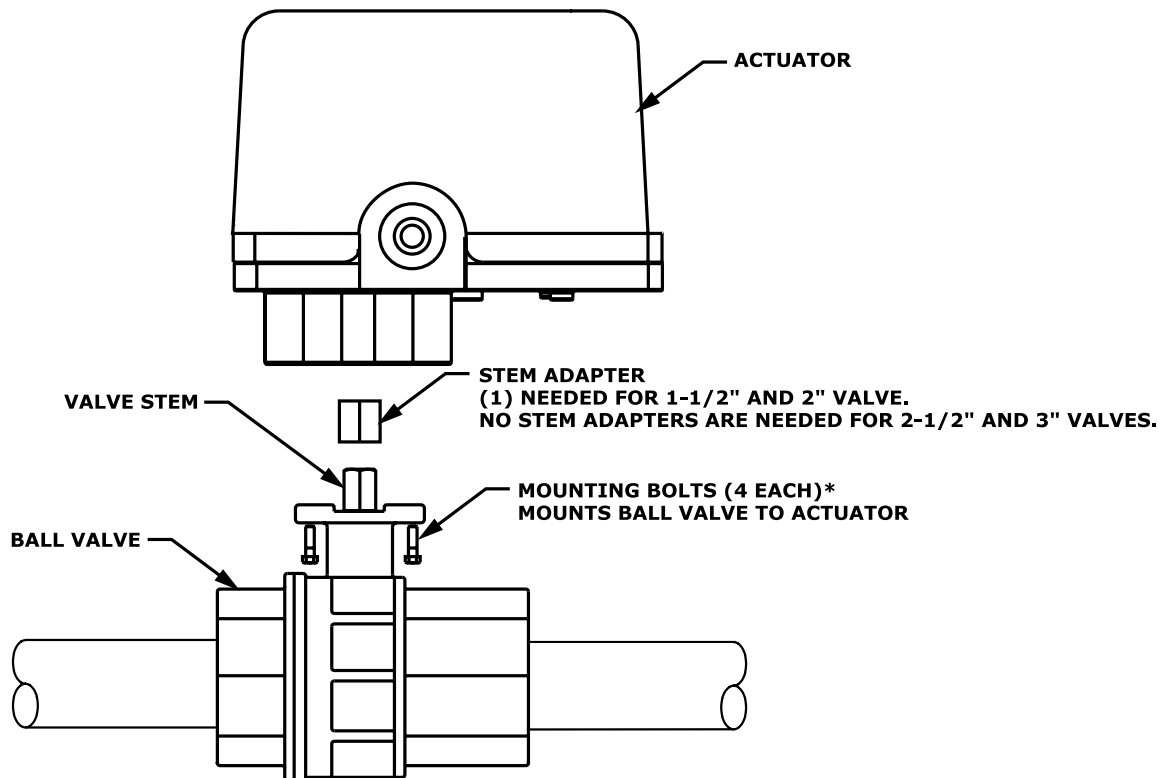

*** FOR 1-1/2 & 2" VALVE USE (4) M6 X 16MM HEX HEAD SCREWS
TIGHTEN DOWN WITH A 6MM OPEN END WRENCH.
FOR 1-1/2 & 2" VALVE USE (4) M8 X 20MM HEX HEAD SCREWS
TIGHTEN DOWN WITH A 8MM OPEN END WRENCH.**

3.0 ADJUSTING THE TIMER

- 3.1 Refer to FIGURE 1 for button description
- 3.2 Firmly push the mode key and up arrow key simultaneously and hold for a full 3 seconds. The display will change to allow adjustment to the valve closed and open times.
- 3.3 Use the up or down arrow keys to set the hours you wish the valve to remain closed. Press the enter key. Use the up and down arrow keys to select the minutes you wish the valve to remain closed. Press the enter key. Use the up or down arrow key to set the minutes you wish the valve to remain open. Press the enter key. Use the up or down arrow key to set the seconds you wish the valve to remain open. Press the enter key. Your timer is now set.

4.0 REQUIRED MAINTENANCE

Periodically check the valve for the following:

- 4.1 Press and hold the Mode and Enter key for 3 seconds to verify valve rotation. The display should say "OVER-RIDE" and the valve should rotate from closed to open and back to closed.
- 4.2 Check actuator to valve connection area for debris which could impede proper operation.
- 4.3 Check wires and/or electrical connections for signs of damage.
- 4.4 Check valve for leaks. If leaks are present, remove pressure from the system and replace the ball valve.
- 4.5 Check fasteners for tightness.

Note: Service work to be done by qualified personnel only! Always remove pressure and power from the unit before servicing.

TROUBLE SHOOTING		
PROBLEM	CAUSES	SOLUTION
Unit will not operate (No display on LCD)	No power	Check power supply. Check circuit breakers or fuses. Check to see if circuit has a remote power on/off switch.
	Fuse F1 is blown	Replace Fuse F1.
Unit will not operate ("VALVE FAULT" displayed on LCD)	The control board did not sense that the next position, closed or open, was reached for a period of 15 seconds	Turn power off and back on. Press and hold Mode and Enter buttons simultaneously for 3 seconds. If "OVERRIDE" is displayed but valve does not rotate, fuse labeled F2 on bottom board is blown. Replace fuse. If "OVERRIDE" is displayed, valve rotates continuously and valve fault reappears, then the optic sensor has failed. Contact factory. If "OVERRIDE" is displayed, valve rotates and the timer closed time appears, then the "VALVE FAULT" has been cleared.
Unit will not operate (LCD display working properly)	Faulty actuator/motor/valve assembly	Press and hold the Enter and Mode keys simultaneously for 3 seconds. If the actuator motor turns but the valve doesn't, check for a broken or loose valve stem. If the stem is broken, replace the valve. If this is not the problem, replace the entire unit. If the motor will not turn after power is applied directly to it, the motor has failed and the unit must be replaced.
Valve binds during rotation	Ball valve seats worn	Replace the ball valve.
	Ball valve ball clogged or damaged	Free valve of any debris. If valve is damaged, replace.
Ball valve leaks prematurely	Defective ball valve	Replace ball valve.
	Valve set on short cycle time	Ball valve should be replaced at some time between 100,000 and 150,000 cycles (will vary with application). If cycle times are set below 5 minutes, then the ball valve will most likely require replacing within the warranty period (based on 24-hour per day operation). This is considered normal wear and not covered under warranty.
Display reads "OPEN" or "CLOSED" and valve is in the opposite position	Power Interruption	Press and hold the Enter and Mode keys simultaneously for 3 seconds. Valve will rotate to the closed position.

VAN AIR PARTS AND SERVICE

PHONE: 888-606-9303

FAX: 814-774-3643

E-MAIL: vanair@vanairsystems.com