

**SALES EXAMPLE ONLY  
NOT FOR CONSTRUCTION**

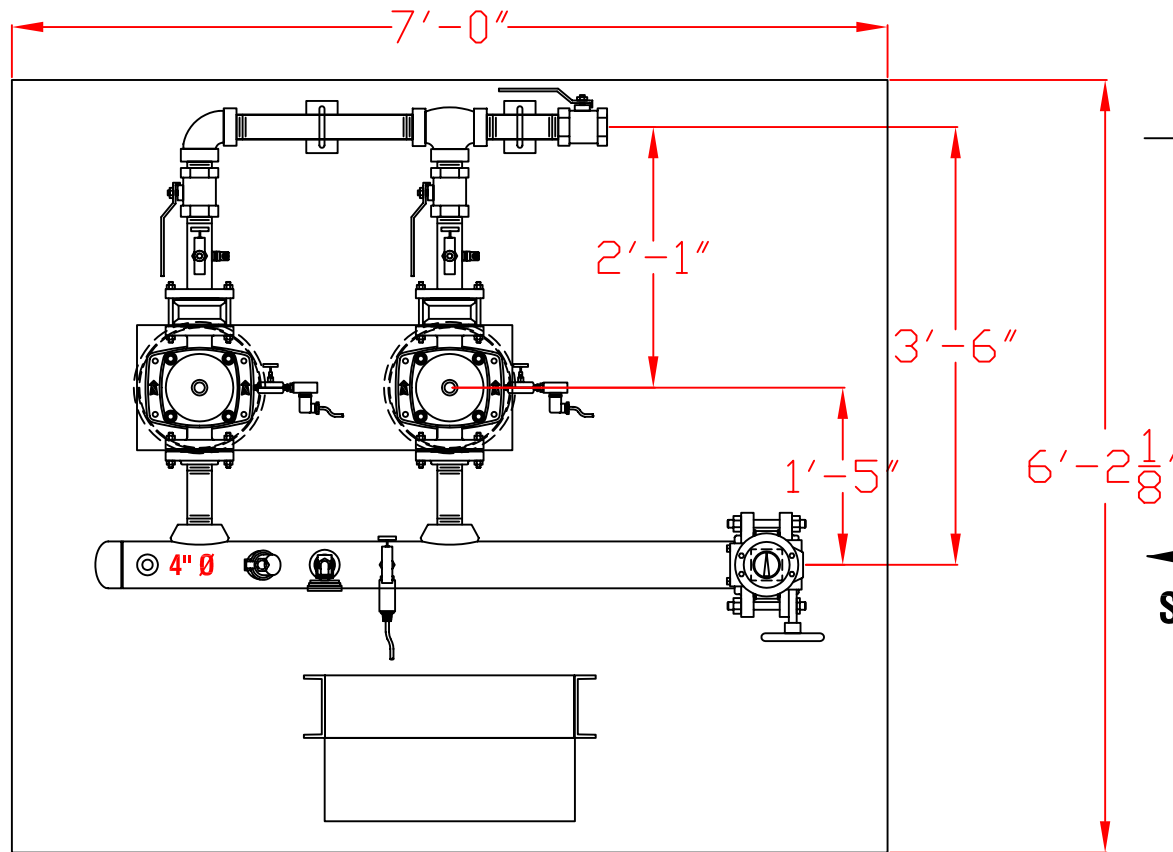

→ **DISCHARGE**

← **SUPPLY**

**STATION CAPACITY**  
**150 GPM @ 700' TDH (300 PSI)**  
**25 HP DUPLEX 460/3/60**  
**4" FLANGE x 2" FNPT CONNECTIONS**

**25 HP  
CONTROL PANEL**

**INLINE BOOSTER PACKAGE  
CR 15-12 DUPLEX**

INLINE BOOSTER PACKAGE CR 15-12 SKID PLAN VIEW	
DRAWN BY: MJH	CHECKED:
DATE: 02-14-2008	APPROVED: JDC
SCALE: NTS	
DRAWING NUMBER:	
XXXX08-M1	
REV: 0	SHEET: 1 OF 2

NO.	DATE	REVISION	BY

THIS DRAWING AND THE INFORMATION SHOWN HEREON IS THE EXCLUSIVE PROPERTY OF TORRENT ENGINEERING AND EQUIPMENT, LLC, AND SHALL NOT BE REPRODUCED OR DISCLOSED TO ANY THIRD PARTY WITHOUT PRIOR WRITTEN CONSENT FROM THE COMPANY.

**TORRENT** Engineering and Equipment  
 P.O. BOX 270 MILFORD, IN 46542 USA  
 Phone: (574)-658-3200 Fax: (574)-658-3229 www.torrentee.com