

- Extremely Efficient Separation of Entrained Liquids and Mists from a Gas or Vapor Flow.
- 100% Removal of Liquid Particles 8.0 Microns and Larger.
- Low Pressure Drop.
- Superior Design.
- Rugged Construction/Long Life.
- Stock or Custom Designed.
- No Maintenance.

### Design Advantages:

The Anderson Pocket Type Vane has several advantages over our competition's Hook-Type Vanes.

- Anderson Vanes have a shielded pocket for uninterrupted liquid collection and drainage. The draining liquid is protected from re-entrainment and thus able to handle an increased volume.
- Anderson Vanes have a lower pressure drop with increased capacity as compared to Hook-Type Vanes.
- Anderson Vanes provide a more laminar flow with lower turbulence due to advanced flow profile design.
- Anderson Vane Bundles are smaller in size compared to Hook-Type Vanes in similar applications. This results in a smaller more efficient and economical vessel design.

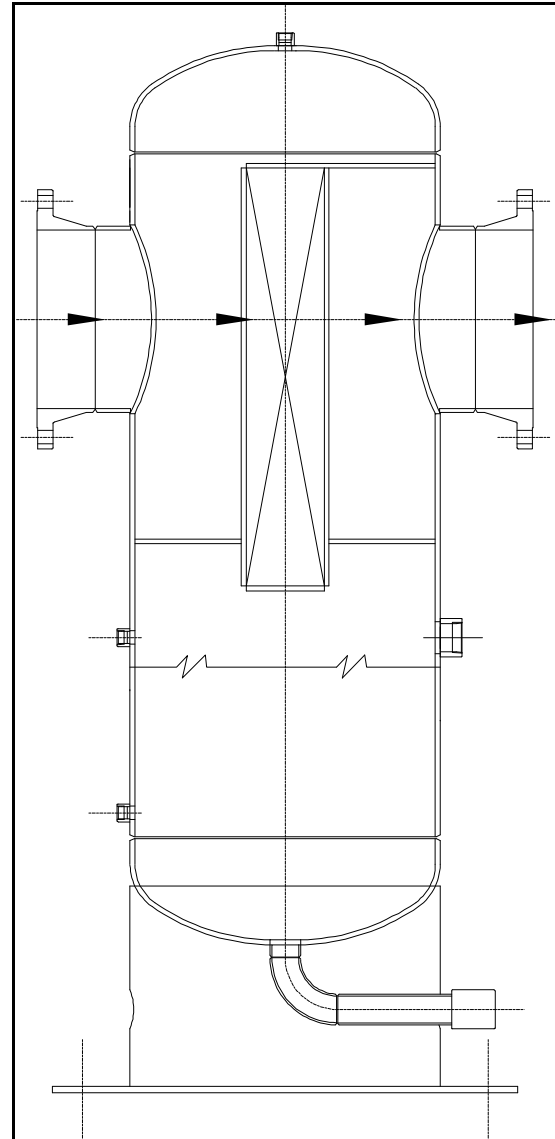

### Typical Applications:

Anderson Vane Separators are used in applications where efficient liquid-gas separation is required. Typical applications are found at Chemical & Petrochemical Plants, Refineries, and Natural Gas Pipelines. These applications include.

- Removal of Condensed Water and Lube Oil in Air Compressor Lines.
- Removal of Condensate and Lube Oil in Steam Lines and Exhaust Systems.
- Removal of Compressor Lube Oil and Moisture after Gas Compressor and Compressor Aftercoolers.
- Removal & Recovery of Glycol Downstream of Glycol Contactors.
- Removal of Liquids Ahead of Desiccant Beds to Improve Desiccant Life.
- Removal of Amines and Absorption Oil From Natural Gas.
- Product Recovery.

### Principal of Operation:

The success of the Anderson Separation Vane is rooted in simple physics principles of centrifugal force, impingement and gravity. The liquid laden gas entering the vane separator is a mixture of low density gas and high density liquid. As this mixture passes through the vane bundle, it is forced to change directions several times. The low density gas can easily negotiate this tortuous path, but because of momentum, the high density liquid is unable to change direction without impinging upon the vane wall.

At each change in direction, a centrifugal force is imparted on the gas liquid mixture, which throws the liquid particles against the wetted vane walls. These liquid droplets coalesce into larger particles, absorb other droplets striking the vane, convert to sheet flow and travel towards the vane pockets. Once the liquid enters the vane pockets, they are isolated from the gas stream, and drain by gravity into the liquid sump.

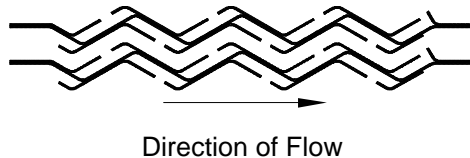

### Efficiency

Anderson Vane Separators will remove 100% of all liquid particles 8.0 microns and larger when operating between 0 and 110% design flowrate. When operating at the design flowrate, a separation efficiency of 100% of 5.0 microns and larger is expected.

The Separation efficiency can be improved to 100% of 3.0 microns by the addition of an inlet coalescer. Separation efficiency decreases on droplets of decreasing size. In order to separate these smaller droplets, the vane bundle must be preceded by an inlet coalescer. The coalescer will increase the size of incoming liquid droplets so that they can be removed by the separation vanes. The inlet coalescer can either be a special hookless vane bundle located in the inlet nozzle, or a stainless steel wire mesh pad mounted on the vane face.

### Design Features/Options:

Anderson Vane Separators are available in configurations other than the standard inline configuration. The optional configurations are as shown below:

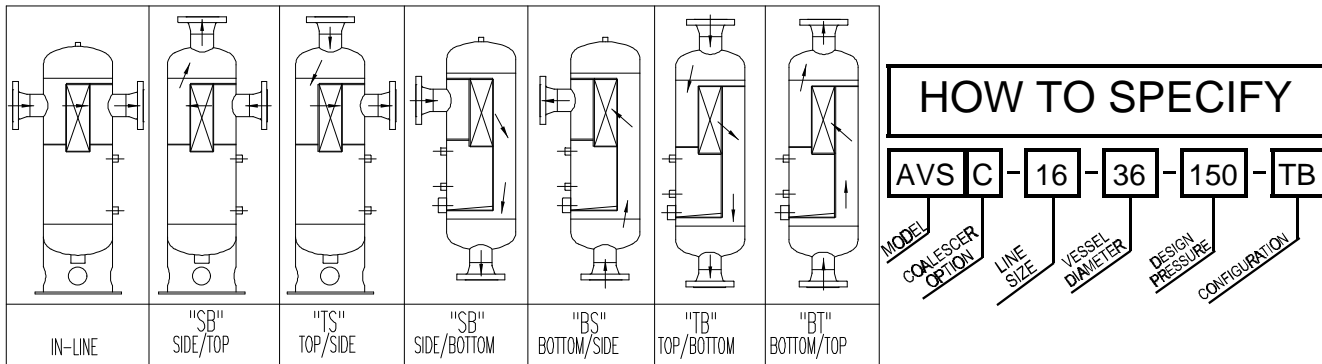

- Available Gauge Glass/Float Trap/Sight Flow Indicator/Liquid Level Controller/Dump Valve upon request.
- Separation Vanes available in carbon steel, 304L and 316L Stainless Steel; Special Alloys upon request.
- Custom engineered, designed and fabricated.
- ASME Code Constructed.
- Optional Coalescer for Improved Efficiency.
- Optional Removable Vanes.

## ANDERSON SEPARATOR

A.S.M.E. CODE STAMPS



**The Clark•Reliance® Corporation**  
16633 Foltz Industrial Parkway, Strongsville, OH 44149 U.S.A.  
Tel: 440-572-1500 Fax: 440-238-8828

