

**SALES EXAMPLE ONLY  
NOT FOR CONSTRUCTION**

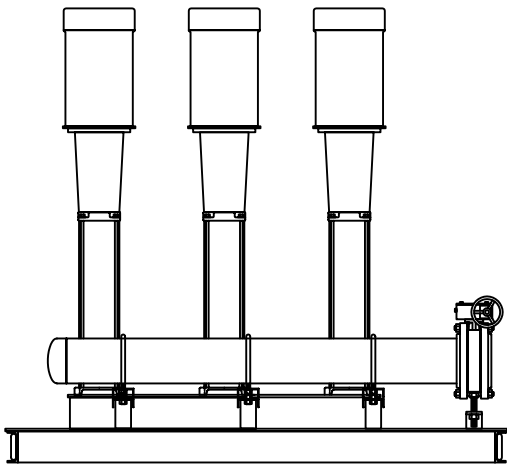

# **VERTICAL CONFIGURATION INLINE BOOSTER PACKAGE CR 45-8-1**

THIS DRAWING AND THE INFORMATION SHOWN HEREON IS THE EXCLUSIVE PROPERTY OF TORRENT ENGINEERING AND EQUIPMENT, LLC, AND SHALL NOT BE REPRODUCED OR DISCLOSED TO ANY THIRD PARTY WITHOUT PRIOR WRITTEN CONSENT FROM THE COMPANY.

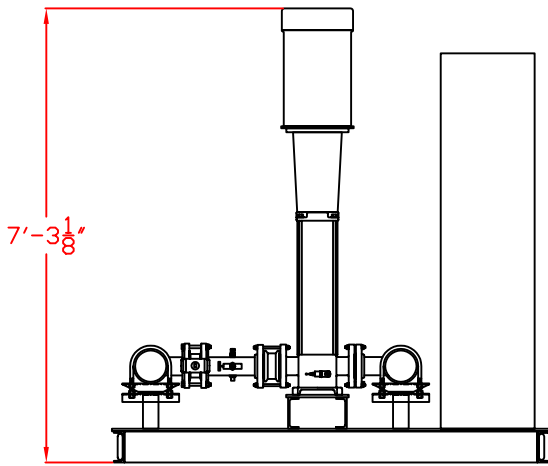
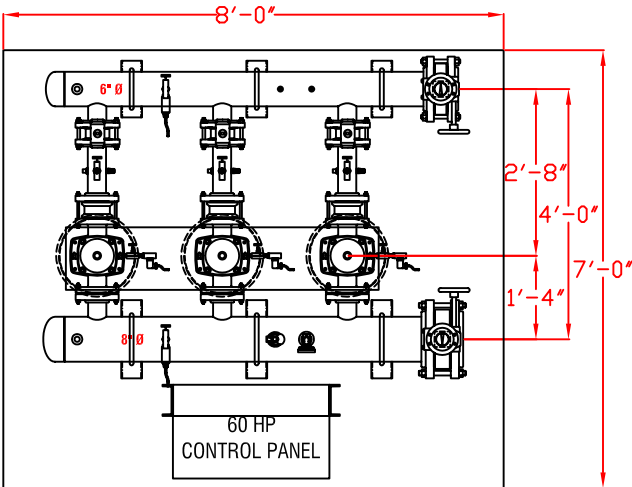

**TORRENT** Engineering and Equipment

P.O. BOX 270 MILFORD, IN 46542 USA  
Phone: (574)-658-3200 Fax: (574)-658-3229 www.torrentee.com